



**Cycle Computer - S1.41**

Congratulations!

You have decided for a cycle computer to help you achieve your health & wellness. It gives you the true image of your work out in precise way.

S1.41 is designed to give feedback required by the most discerning cyclists, in which it is with all the functionality on one large easy to read display.

S1.41 is a premier cycle computer for your challenge ride. Altitude functions with the wireless technology lets you enjoy their cycling and riding ascending as well.

Before using S1.41, please read through the manual that guides you on how to operate it correctly & quickly. S1.41 offers you very useful features to customize your exercise.

S1.41 offers you very useful features to customize your exercise and gain the best & accurate measurement. After exercise, you may view your fitness result by pressing the button. It would be better to keep this manual for reference.

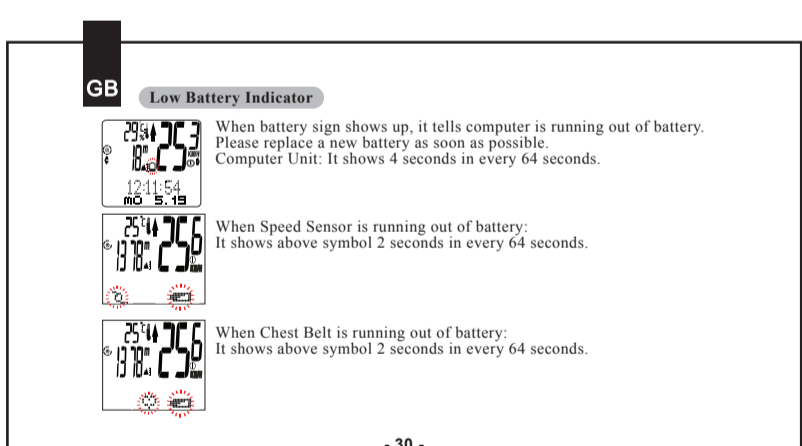
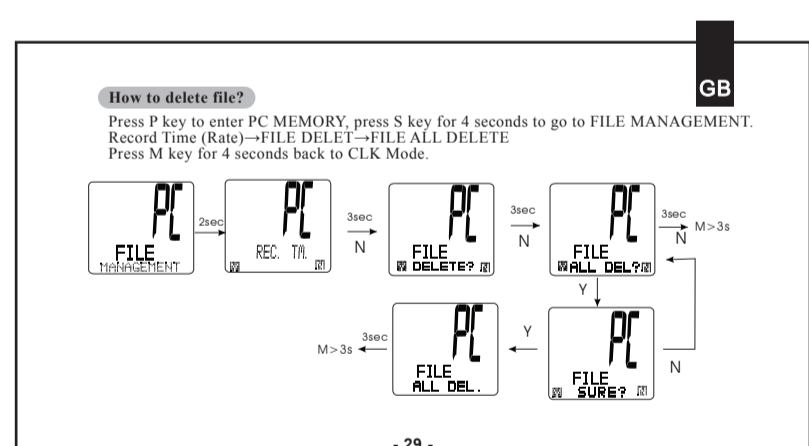
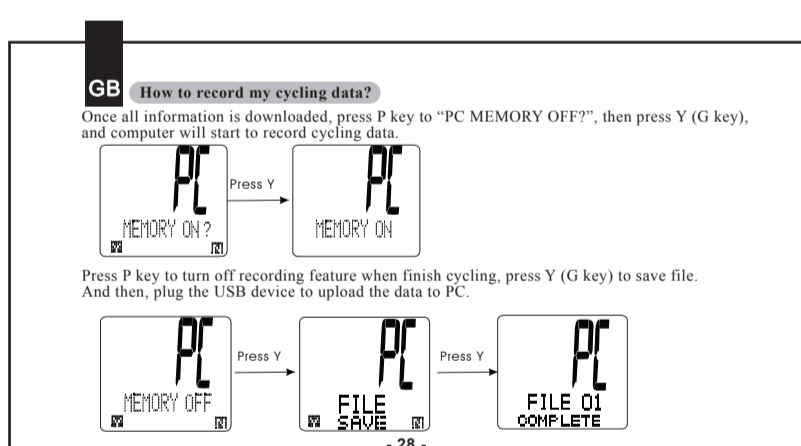
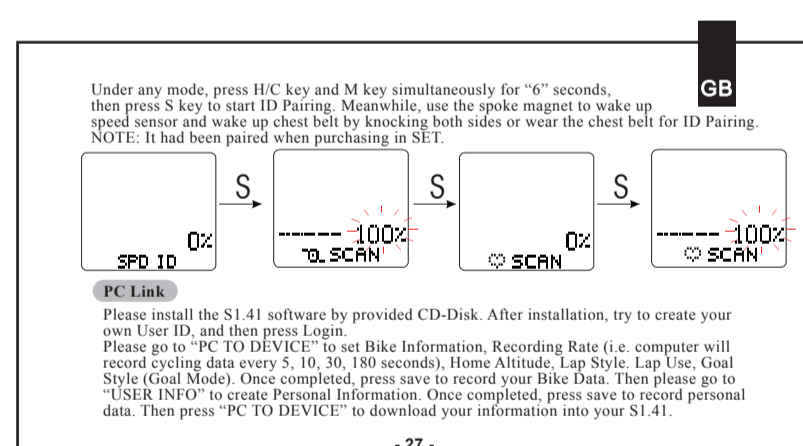
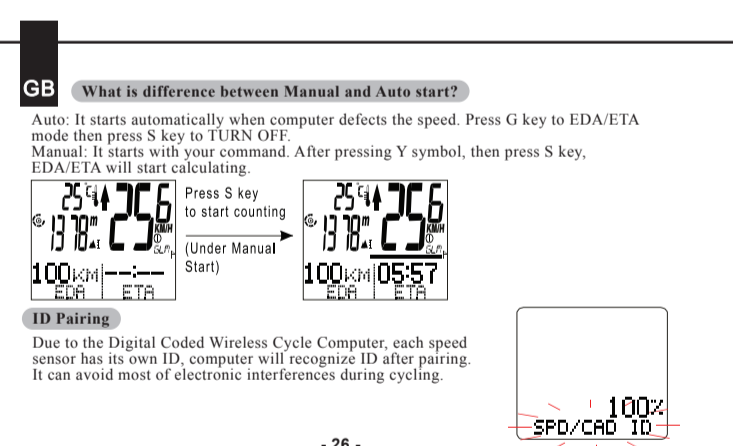
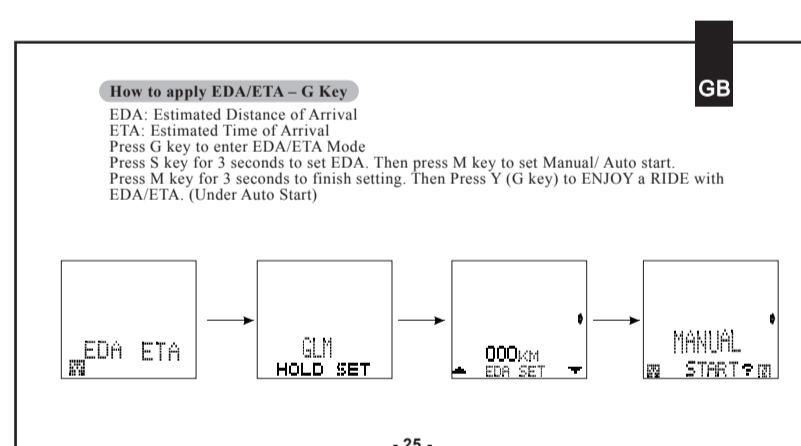
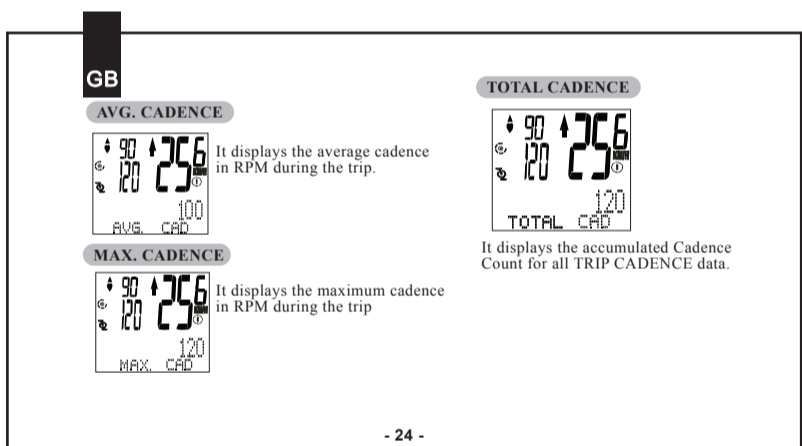
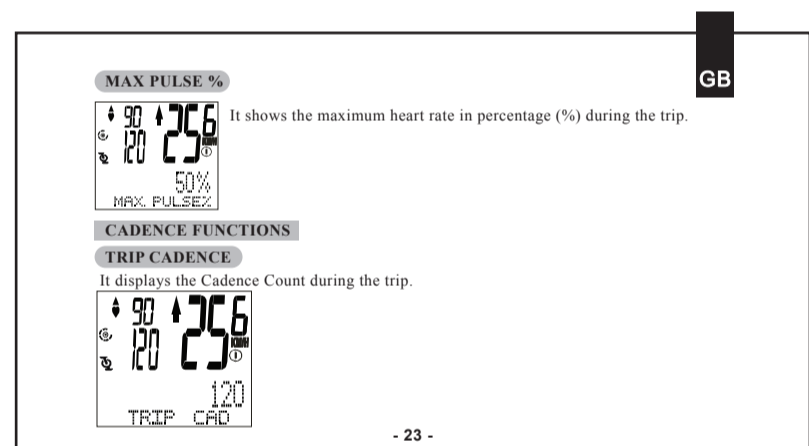
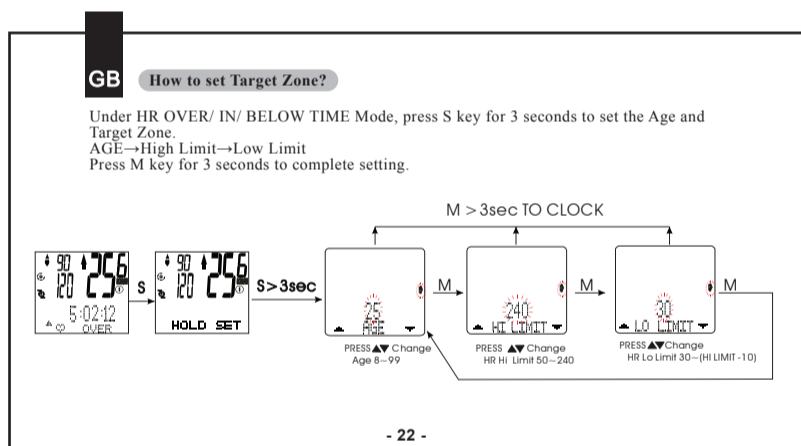
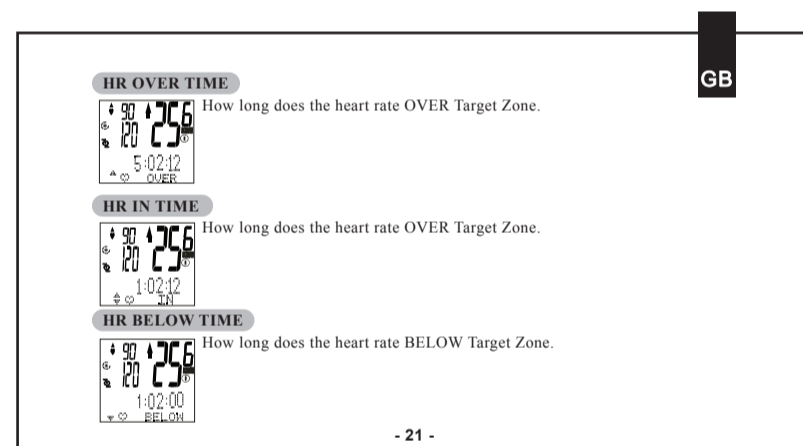
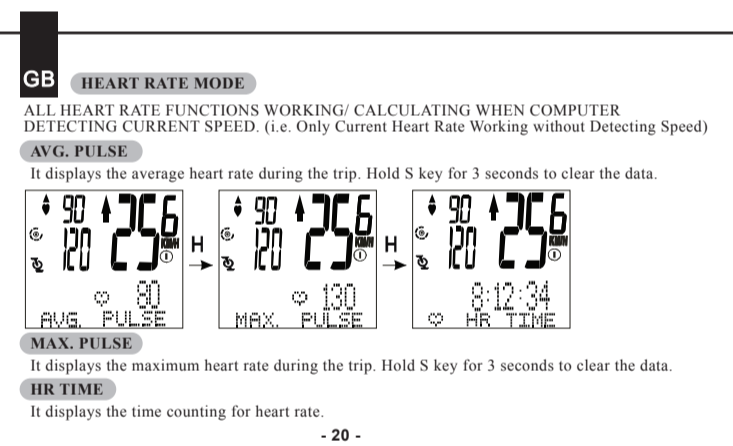
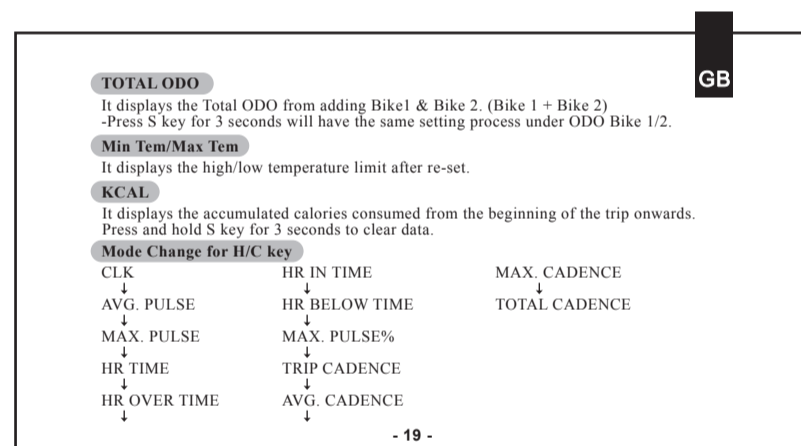
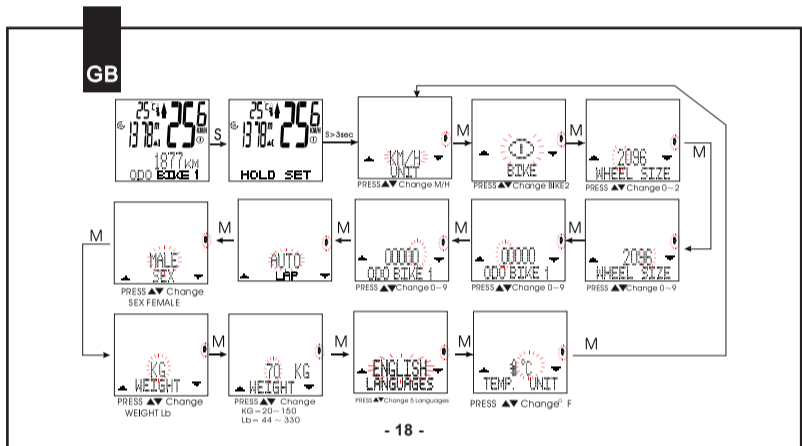
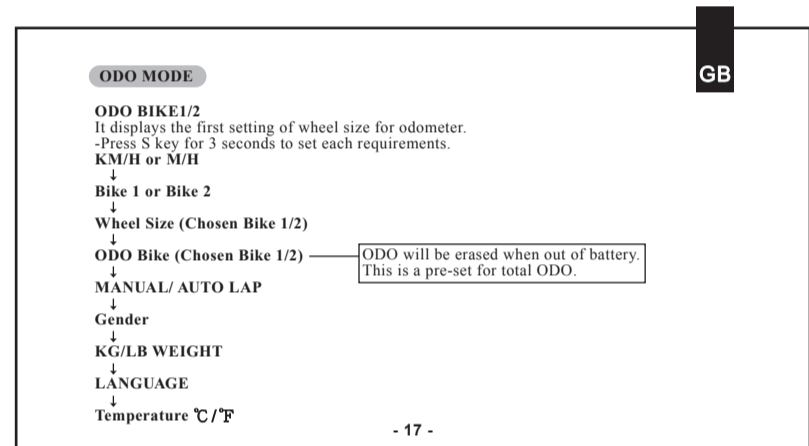
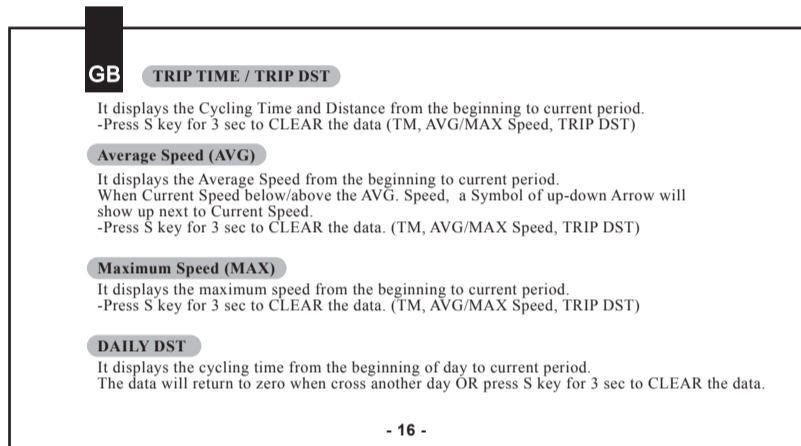
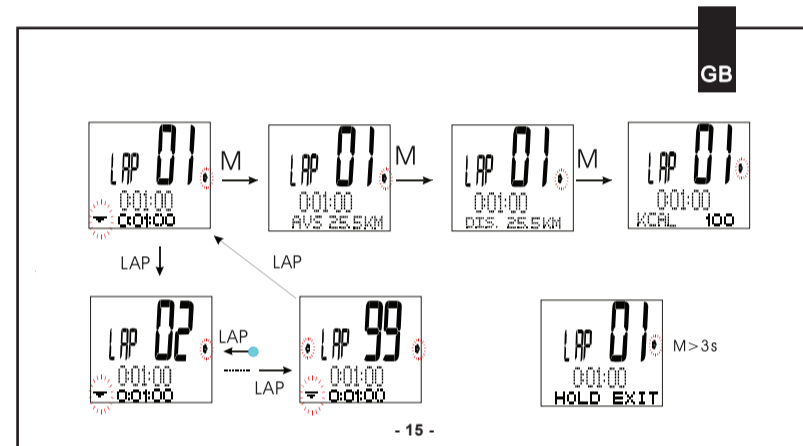
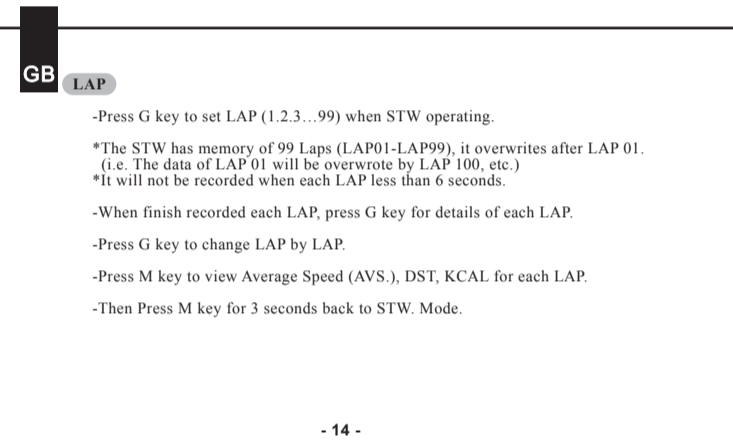
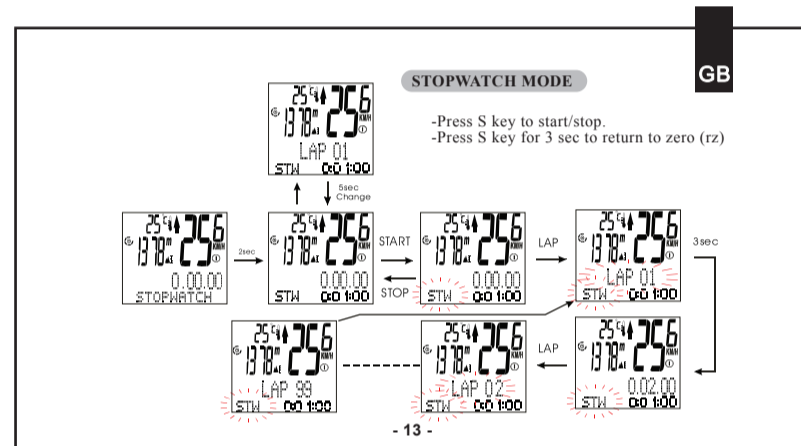
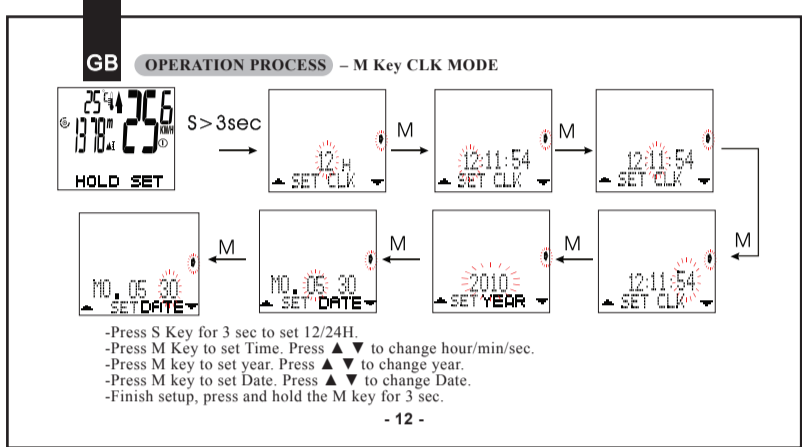
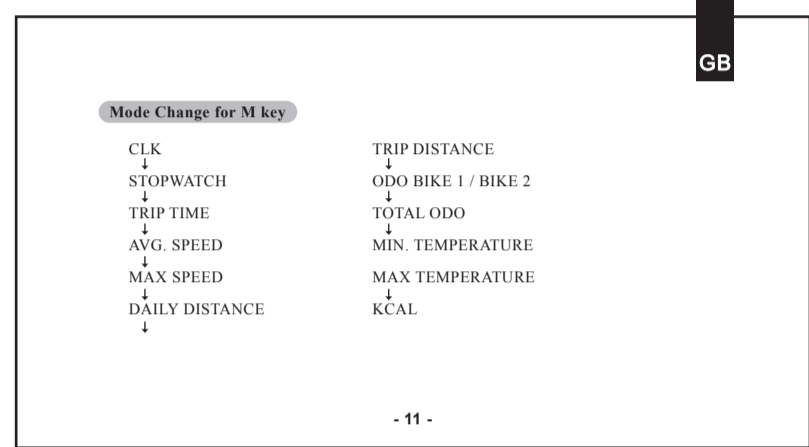
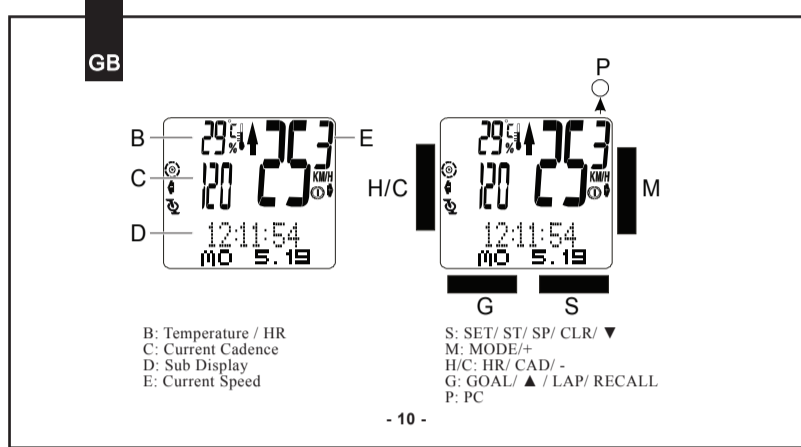
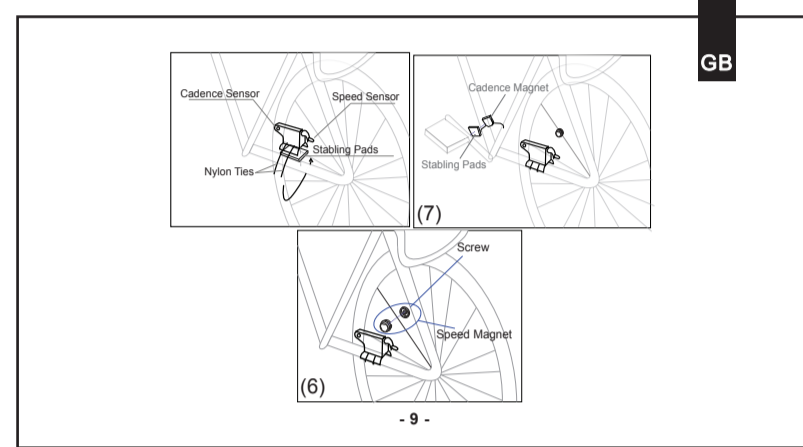
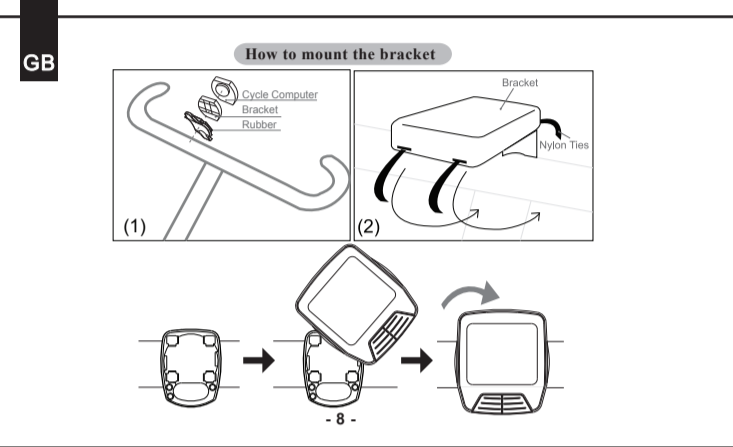
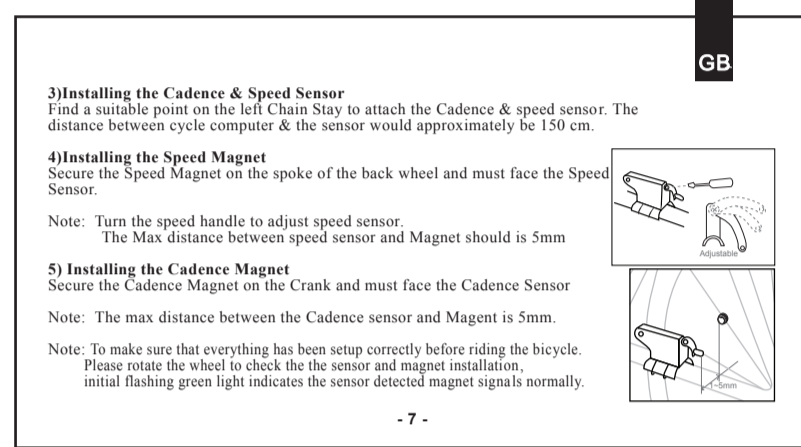
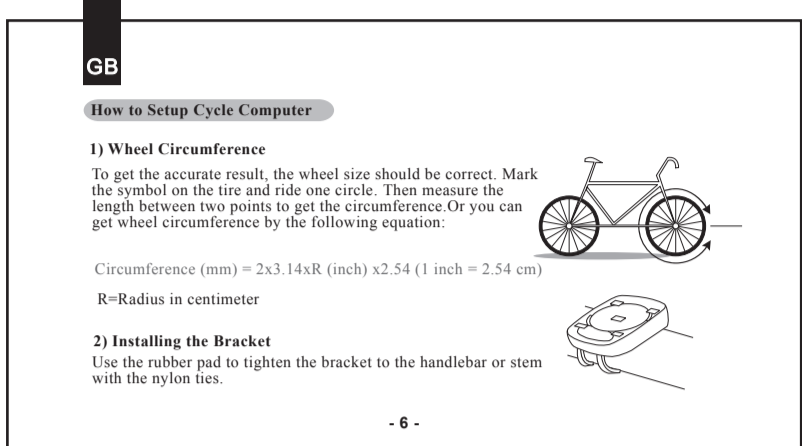
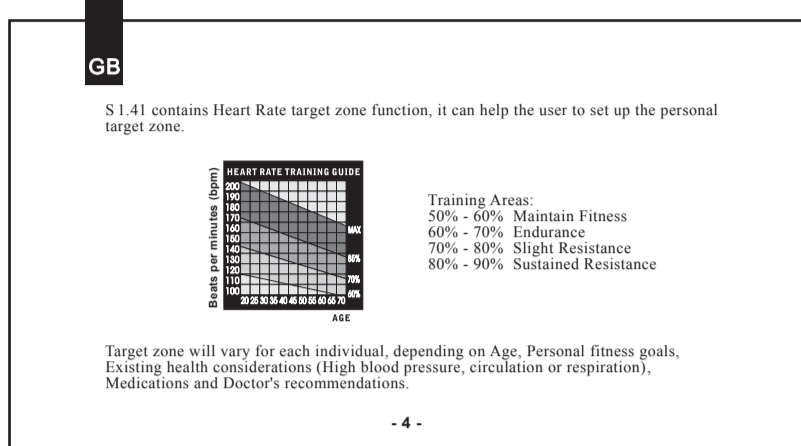
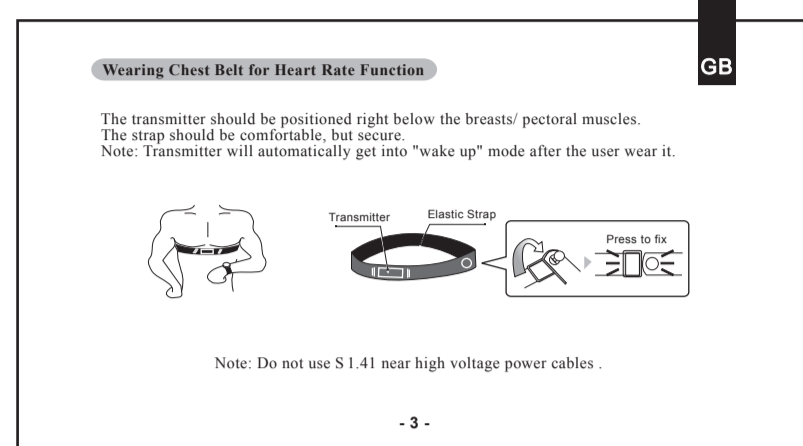
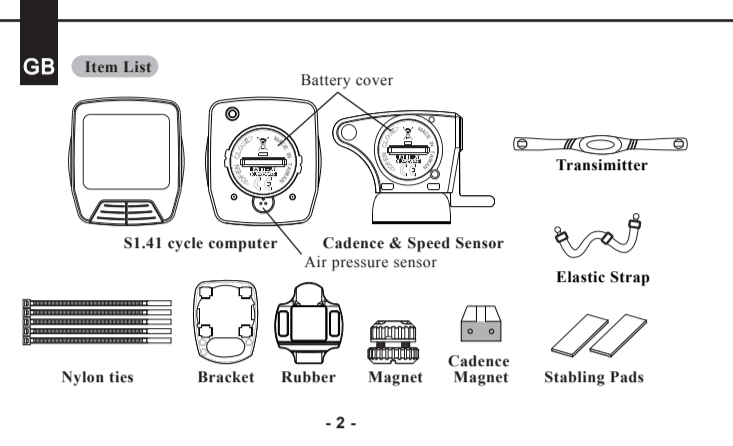

**MAINTENANCE**

**S1.41 cycle computer**  
If the display contrasts changes and figures become faint, it's time to replace the battery. Consider changing the computer sensor and transmitter batteries at the same time.

**NOTE:** Do not expose S1.41 computer to extremely cold or hot temperatures i.e. don't leave the unit in direct sunlight for extended period of time.

**Sensor**  
Check the position of sensor and magnet periodically. For current measurement, the sensor, magnet should not get wet / rust, otherwise it may cause function error.

**Bracket / Magnet / Sensor band**  
The above items can be rinsed in surface fresh water or washed with a mild soap.

**Battery replacement**

**S1.41 cycle computer**  
Unscrew the back cover. Look closely at the battery. Gently remove the battery and replace it with a new battery model CR2032. The (+) side should be facing up.

**Sensor**  
Unscrew the back cover. Look closely at the battery. Gently remove the battery and replace it with a new battery model CR2032. The (-) side should be facing up.

**TROUBLESHOOTING**

**Q1. Display is black or very light:**  
The battery power may be low. Try a new battery to make sure the battery is installed correctly.

**Q2. Display becomes dark or balk:**  
The unit is too hot. Place the unit in a shaded area, and it will return to normal.

**Q3. The unit operates slowly or struggled:**  
The unit is too cold. Warm the unit, and it will return to normal.

**Q4. Date in display varies enormously:**  
Check your surroundings for electro magnetic or high energy interference and move away from the source of interference.

**Q5. Data in display shows slowly:**  
The unit may be affected by low temperature factor but it didn't influence the function reading. When the temperature rises, the data reading will back to the normal.

**Q6. Current speed does not appear:**  
It may be caused by the following situation: the distance & position between magnet and sensor to adjust or low battery power.

**SPECIFICATIONS**

	Receiver	Cadence & Speed Sensor	Transmitter / Belt
Operating Temperature	0°C - 40°C	0°C - 40°C	0°C - 40°C
Storage Temperature	-10°C - 50°C	-10°C - 50°C	-10°C - 50°C
Emitted Frequency	2.4GHz	2.4GHz ± 10%	2.4GHz ± 10%
Battery	3 volt lithium 2032 cell	3 volt lithium 2032 cell	3 volt lithium 2032 cell
Weight	30.6 grams	20 grams	65 grams ± 5%

Stopwatch Range : 0-29(hour) : 59(minute) : 59(second)  
Accuracy 1/100 seconds

Timer Range : 0-29(hour) : 59(minute) : 59(second)

SPEED : 0-99.9KM/H/0-62.4M/H  
TM : 0:00:00-59:59:59  
MXS : 99.9KM/H, 62.4M/H  
AVS : 99.9KM/H, 62.4M/H  
TRIPDIST : 0.00-999.99KM, 624.99MI  
ODOBIKE1 : 0-999999 - KM/0-624999ML  
ODOBIKE2 : 0-999999 - KM/0-624999ML  
TOTODO : 0-999999 - KM/0-124998ML  
ACT. ALTI : 699-3999(m) - 999-9999(ft)  
ALTI BIKE1 (0-999999(m)) ALTI BIKE2 (0-999999(m))  
TOT. ALTI : 0-199998(m) MAX. ALTI : 3999(m) 9999(ft)  
TRIPCLIMB : 0-9999(m) ALTI GAIN : 0-9999(m)  
WHEEL SIZE : (2:100-299)(mm)  
AVCAD : 999  
MAXCAD : 999 KCAL : 999999

**LIMITED WARRANTY**  
This product is for three years limited warranty commencing on the date of purchase. The product will be free from defects in material and workmanship for one and half year from the date of production.

Warranty does not cover the batteries, damages due to misuse, abuse or accidents, cracked or broken cases, negligence of precautions, improper maintenance or commercial use.

Warranty is void if the repairs are done by non authorized service technician.

The warranties contained herein are expressly in lieu of any other warranties including implied warranty of merchantability and/or fitness for purpose. In no event shall manufacturer be liable for any damages, direct or incidental, consequential or special, arising out of or related to the use of this manual or the products described herein.

**Important Health Notice!**  
Please read over the following information before using the Cycle computer.

- Never use the cycle computer in combination with other medical / implanted electronic equipment and device (especially heart pacemakers, EKG equipment, TENS equipment, cardio-pulmonary machines and pacemaker).
- If you are severely ill or pregnant, please consult your doctor before using cycle computer.
- Keep this device away from children. It contains batteries, which might be swallowed by children.
- As with most electronic receiving devices, there can sometimes be interference that causes inaccurate display readings. Avoid using your cycle computer near common sources of interference. These include high voltage power lines, air conditioning motor units, fluorescent lights, wristwatches, mobiles and computer.

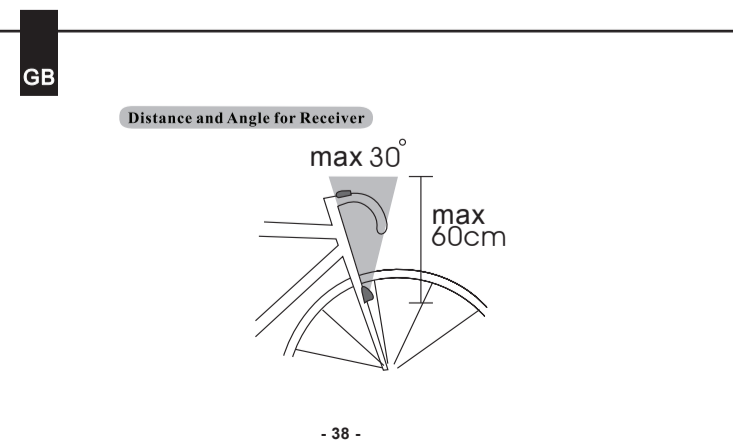

**Wheel Size Chart**

Wheel Size (mm)	Wheel Size (inch)
14.5 x 1.50	10.00
16.5 x 1.75	12.00
18.5 x 1.75	13.50
18.5 x 1.50	11.82
18.5 x 1.50	11.82
18.5 x 1.50	11.82
18.5 x 1.50	11.82
18.5 x 1.50	11.82
18.5 x 1.75	13.50
19.5 x 1.75	14.50
20.5 x 1.75	15.50
21.5 x 1.75	16.50
22.5 x 1.75	17.50
23.5 x 1.75	18.50
24.5 x 1.75	19.50
25.5 x 1.75	20.50
26.5 x 1.75	21.50
27.5 x 1.75	22.50
28.5 x 1.75	23.50
29.5 x 1.75	24.50
30.5 x 1.75	25.50
31.5 x 1.75	26.50
32.5 x 1.75	27.50
33.5 x 1.75	28.50
34.5 x 1.75	29.50
35.5 x 1.75	30.50
36.5 x 1.75	31.50
37.5 x 1.75	32.50
38.5 x 1.75	33.50
39.5 x 1.75	34.50
40.5 x 1.75	35.50
41.5 x 1.75	36.50
42.5 x 1.75	37.50
43.5 x 1.75	38.50
44.5 x 1.75	39.50
45.5 x 1.75	40.50
46.5 x 1.75	41.50
47.5 x 1.75	42.50
48.5 x 1.75	43.50
49.5 x 1.75	44.50
50.5 x 1.75	45.50
51.5 x 1.75	46.50
52.5 x 1.75	47.50
53.5 x 1.75	48.50
54.5 x 1.75	49.50
55.5 x 1.75	50.50
56.5 x 1.75	51.50
57.5 x 1.75	52.50
58.5 x 1.75	53.50
59.5 x 1.75	54.50
60.5 x 1.75	55.50
61.5 x 1.75	56.50
62.5 x 1.75	57.50
63.5 x 1.75	58.50
64.5 x 1.75	59.50
65.5 x 1.75	60.50
66.5 x 1.75	61.50
67.5 x 1.75	62.50
68.5 x 1.75	63.50
69.5 x 1.75	64.50
70.5 x 1.75	65.50
71.5 x 1.75	66.50
72.5 x 1.75	67.50
73.5 x 1.75	68.50
74.5 x 1.75	69.50
75.5 x 1.75	70.50
76.5 x 1.75	71.50
77.5 x 1.75	72.50
78.5 x 1.75	73.50
79.5 x 1.75	74.50
80.5 x 1.75	75.50
81.5 x 1.75	76.50
82.5 x 1.75	77.50
83.5 x 1.75	78.50
84.5 x 1.75	79.50
85.5 x 1.75	80.50
86.5 x 1.75	81.50
87.5 x 1.75	82.50
88.5 x 1.75	83.50
89.5 x 1.75	84.50
90.5 x 1.75	85.50
91.5 x 1.75	86.50
92.5 x 1.75	87.50
93.5 x 1.75	88.50
94.5 x 1.75	89.50
95.5 x 1.75	90.50
96.5 x 1.75	91.50
97.5 x 1.75	92.50
98.5 x 1.75	93.50
99.5 x 1.75	94.50
100.5 x 1.75	95.50
101.5 x 1.75	96.50
102.5 x 1.75	97.50
103.5 x 1.75	98.50
104.5 x 1.75	99.50
105.5 x 1.75	100.50
106.5 x 1.75	101.50
107.5 x 1.75	102.50
108.5 x 1.75	103.50
109.5 x 1.75	104.50
110.5 x 1.75	105.50
111.5 x 1.75	106.50
112.5 x 1.75	107.50
113.5 x 1.75	108.50
114.5 x 1.75	109.50
115.5 x 1.75	110.50
116.5 x 1.75	111.50
117.5 x 1.75	112.50
118.5 x 1.75	113.50
119.5 x 1.75	114.50
120.5 x 1.75	115.50
121.5 x 1.75	116.50
122.5 x 1.75	117.50
123.5 x 1.75	118.50
124.5 x 1.75	119.50
125.5 x 1.75	120.50
126.5 x 1.75	121.50
127.5 x 1.75	122.50
128.5 x 1.75	123.50
129.5 x 1.75	124.50
130.5 x 1.75	125.50
131.5 x 1.75	126.50
132.5 x 1.75	127.50
133.5 x 1.75	128.50
134.5 x 1.75	129.50
135.5 x 1.75	130.50
136.5 x 1.75	131.50
137.5 x 1.75	132.50
138.5 x 1.75	133.50
139.5 x 1.75	134.50
140.5 x 1.75	135.50
141.5 x 1.75	136.50
142.5 x 1.75	137.50
143.5 x 1.75	138.50
144.5 x 1.75	139.50
145.5 x 1.75	140.50
146.5 x 1.75	141.50
147.5 x 1.75	142.50
148.5 x 1.75	143.50
149.5 x 1.75	144.50
150.5 x 1.75	145.50
151.5 x 1.75	146.50
152.5 x 1.75	147.50
153.5 x 1.75	148.50
154.5 x 1.75	149.50
155.5 x 1.75	150.50
156.5 x 1.75	151.50
157.5 x 1.75	152.50
158.5 x 1.75	153.50
159.5 x 1.75	154.50
160.5 x 1.75	155.50
161.5 x 1.75	156.50
162.5 x 1.75	157.50
163.5 x 1.75	158.50
164.5 x 1.75	159.50
165.5 x 1.75	160.50
166.5 x 1.75	161